

Electro-Luminescent GlowStrip

Installation Instructions

Thank you for your purchase of Superior Panel Technology's GlowStrip. You will find that the GlowStrips provide a very nice soft bluish-green or white lighting that is easy on the eyes and significantly improves the lighting of a cockpit. When used under a glare shield, the GlowStrip will improve the visibility of instruments, nomenclature of switches, breakers and will aid in the reading of charts and maps. The GlowStrip is also a good backup lighting system in the event of a failure of a primary light source. The flexible GlowStrip can also be used to light up other areas like baggage compartments or under seat lighting to light up rear cabins.

The installation tips listed below are for installing the GlowStrips under a glare shield. Similar procedures are used when placing it in other areas.

1. Determine the source of power for the GlowStrip. Protect the circuit with a two-amp breaker or fuse. We recommend the use of our Pulse-Width Modulating Dimmer (SPTPWMLDS) for smooth continuous dimming of the lamps.
2. The inverter supplied with your kit is for either a 14 or 28 volt system. You can verify this by looking at your part number.

A part number of GS2-36-14W would indicate:

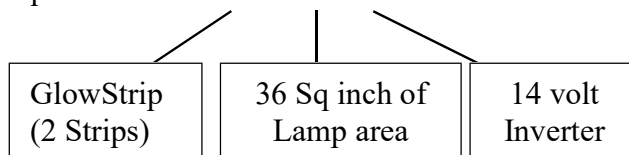

W=White G=Green

- Inverter wiring: The RED wire is for input voltage. Connect the BLACK wire to a secure aircraft ground. The YELLOW and WHITE wires are the output voltage wires that connect to the GlowStrip lamp.
3. Two conductor shielded hookup wire is included with the kit and is used for the wiring between the inverter and the GlowStrip lamps. Solder the white and black wires from the 2 conductor cable to the wire leads coming from the GlowStrip Lamp(s) (see picture). **Note that this is AC voltage so polarity is not a factor!** The GlowStrip Lamps come with 10" leads. It is best to keep the unshielded wire leads to a minimum. Typically the unshielded wires are only 2 to or 3 inches long. Cover the entire assembly with a piece of 5/16" heat shrink tubing.
 4. Drill a 1/4" hole in the appropriate place for the two-conductor wire to pass through the panel. This is normally centered near the top of the panel. Use caution when drilling through your panel. Nothing will ruin your day more than accidentally drilling through a rigid oxygen line or wire bundle. If you are drilling through an overlay be sure to hold it down while drilling to prevent it from cracking. A thin piece of wood with the 1/4" hole drilled in it can be used as a guide to protect the panel, keep the bit from walking and hold the overlay down. The best bit for this operation is a Unibit step bit.
 5. Position the GlowStrip under the glare shield where desired and use a few small pieces of tape to hold in place. Place masking tape around the outside perimeter of the GlowStrip. The masking tape will act as a guide when applying the adhesive primer on the glare shield. A small ampoule of adhesive primer is included your kit. The adhesive primer is not needed on the GlowStrip and is not needed on the glare shield if it is very flat, clean and smooth. Adhesive primer is recommended if the glare shield is made of material, leather or is not a flat and smooth surface. Apply the primer by breaking the barrier in the ampoule where shown on the container and allow it to wick into the brush end. Coat the area within the rectangular area boarded by the masking tape. Allow the primer to thoroughly dry (10-20 minutes). After the primer has dried, remove the remaining release liner on the adhesive tape and adhere the GlowStrip to the glare shield using the masking tape as a guide.

Additional tips:

- Leave a service loop of the two-conductor wire on the backside of the panel were it passes through the top of the panel.
- Connect the 2 conductor wire shield to a good chassis ground at the inverter end.
- It is best to keep the inverter away from antenna cables, wire bundles and close proximity (6") of other radio equipment and in well ventilated area. **THE INVERTER DOES GET WARM- DO NOT INSULATE OR COVER UP INVERTER AS THAT WILL PREVENT IT FROM DISSIPATING HEAT!**
- The inverter can be mounted easily with zip-ties.
- For a clean installation of the two-strip model of GlowStrips the strips can be installed connector ends together leaving just enough space to feed the wire leads toward the panel. Then install black heat shrink over the wire assembly. (See Picture)
- Although flexible lengthwise, the GlowStrips will not make compound curves. Take your time to temporarily position the strips first with masking tape before applying the adhering them permanently into place.
- **THE INVERTERS ARE DESIGNED TO LIGHT UP A SPECIFIC NUMBER OF SQUARE INCHES OF LAMP(S). NEVER ENERGIZE THE INVERTER UNLESS IT IS CONNECTED TO EITHER THE ONE OR TWO LAMPS INCLUDED IN YOUR KIT. REPLACE ANY FAILED LAMP TO PREVENT OVERPOWERING THE REMAINING LAMP (ON A MULTIPLE LAMP KIT).**

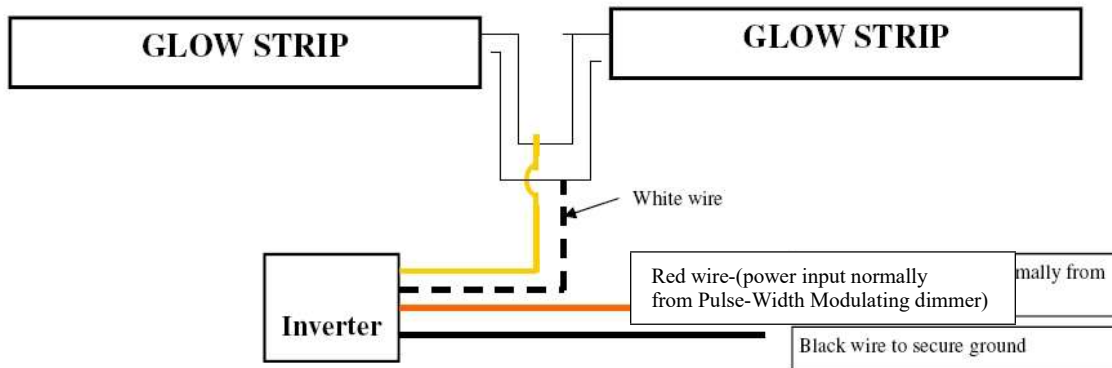
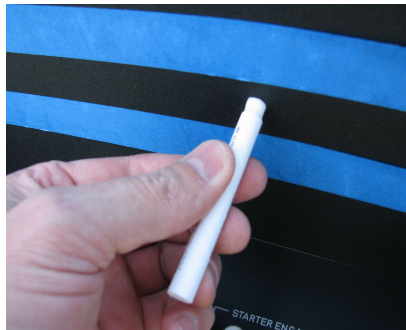
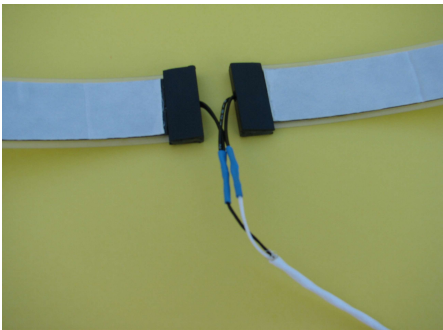

Take one wire from each lamp and connect it to the yellow wire from the inverter.

Take one wire from each lamp and connect it to the white wire from the inverter.

Use shielded wire from the inverter to the lamps. Ground the shield covering on the shielded wire to a secure ground.

Please call 562-776-9494 if any questions.